

### Standalone type



### Rack mount type



### Features

- Integration on system power
- 2 models in 3U 19-inch rackmount and standalone configurations
- 7" touch Panel and buttons for easy on-site operation
- Ethernet port for on-site or remote monitor and control over the system
- Selectable PMBus, CANbus, RS-485, and RS-232 communication protocols
- Support Data/ Event log with date and time (Note.1)
- Support max. 32G SDHC SD card
- Four user programmable relay outputs for conventional remote monitoring or warning
- Web-based monitor/control UI provided for various applications
- 5 years warranty

### Applications

- Industrial automation
- EV Charging station
- Burn-in systems
- UV curing equipment
- Laser diode machines
- Telecommunication systems
- Horticulture lighting
- Building decoration lighting
- Inverter

### GTIN CODE

MW Search: <https://www.meanwell.com/serviceGTIN.aspx>

### Description

CMU2 is a fully digitalized smart controller that can execute tasks of monitoring and controlling over power system. CMU2 implements a 7" LCD touch panel to achieve intuitive operation, and developed a brand new web monitoring page for faster and smarter management. CMU2 not only being used to monitor the operating parameters and data of PSUs, such as output voltage, output current, internal temperature, fan rpm, series number and firmware version, but also can be used to adjust output voltage and current. In addition, it can remotely control single PSU or entire power system through LAN or internet.

### Model Encoding

CMU2 **A** **-R** **B** **C** **D**  
Slot 1 Slot 2 Slot 3

- Extension cards (Note 1)  
 C: CANbus  
 P: PMBus  
 R: RS-232/RS-485/USB  
 #: Blank slot
- R: Rackmount type  
 Blank: Standalone
- Application (Note 2)  
 A: Burn-in test system (optional)  
 B: Horticulture lighting (under development)  
 C: Power management  
 D: EV Charging (under development)  
 E: Inverter management  
 F: Other application (to be defined)
- Series name

Note 1: Fixed by application  
 Note 2: Please contact MEAN WELL or access the installation manual



**SPECIFICATION**

MODEL (Note.9)		CMU2 <input type="checkbox"/>	CMU2 <input type="checkbox"/> -R
OUTPUT	LCD DISPLAY	Display the DC output voltage, current, and status of each PSU	
	LED INDICATOR	Green: Power on/ Normal    Red: Fault/ Abnormal	
	RELAY CONTACT <small>Note.5</small>	4 user programmable channels, 30V/1A	
	ANALOG OUTPUT <small>Note.5</small>	5 user programmable channels, 0-10V	
	DIGITAL OUTPUT <small>Note.5</small>	5 user programmable channels, open collector signal	
INPUT	VOLTAGE RANGE	85 ~ 264VAC; 120-370VDC	
	FREQUENCY RANGE	47 ~ 63Hz	
	CURRENT	0.6A / 115VAC    0.4A / 230VAC	
	ANALOG INPUT <small>Note.5</small>	5 Channels, 0-10V, 12bit resolution	
	DIGITAL INPUT <small>Note.5</small>	5 Channels, open collector signal	
FUNCTION	MONITORED	I/P & O/P Voltage, O/P current, temperature, fan rpm	
	COMM. INTERFACE <small>Note.2</small>	PMBus, CANbus, RS-485, RS-232	
	SD CARD SLOT	SDHC 32GB Max.	
	FIRMWARE UPDATE	Update can be done via SD card or Ethernet access	
	UI LANGUAGE	English, Traditional/Simplified Chinese	
	LOG	Record data and events	
	BUZZER	Alarms, mute	Button click & alarms, mute
COMMUNICATION PROTOCOLS	PMBUS <small>Note.5</small>	PMBus v1.1	
	CANBUS <small>Note.5</small>	CANbus 2.0B	
	NETWORK	Support IEEE802.3, 10/100base network	
	EXTENSION CARDS <small>Note.2</small>	Extension Cards	
ETHERNET SUPPORTED	PROTOCOLS	TCP/IP, NTP, SMTP, Modbus TCP	
	WEB SERVER	Display status of system, parameters, data being logged or download	
EXTENSION CARDS	PMBUS <small>Note.8</small>	2 PMBus ports, PMBus V1.1	
	CANBUS <small>Note.8</small>	2 CANBus ports, CANBus 2.0B	
	USB/RS-232/RS-485	2 USB ports, RS-232 port, RS-485 port	
DISPLAY	LCD PANEL <small>Note.3</small>	7" TFT LCD, resolution 800x480, capacitive touch panel Details of settings please refer to user's manual	
	WORKING TEMP. <small>Note.3</small>	-25 ~ +60°C	
ENVIRONMENT	STORAGE TEMP.	-40 ~ +60°C	
	VIBRATION	10 ~ 500Hz, 2G 10min./1cycle, 60min. each along X, Y, Z axes	
SAFETY & EMC (Note 6)	SAFETY STANDARDS	IEC62368-1, BS EN/EN62368-1 approved	
	WITHSTAND VOLTAGE <small>Note.4</small>	I/P-O/P:3KVAC    I/P-FG:2KVAC    O/P-FG:0.7KVDC	
	ISOLATION RESISTANCE <small>Note.4</small>	O/P-FG:100M Ohms / 500VDC / 25°C / 70% RH	
	EMC EMISSION	Compliance to BS EN/EN55032 (CISPR32) Conduction Class B, Radiation Class A; BS EN/EN61000-3-2,-3	
EMC IMMUNITY	Compliance to BS EN/EN61000-4-2,3,4,5,6,8,11, BS EN/EN61000-6-1(BS EN/EN50082-2), light industry level, criteria A		
OTHERS	MTBF	680K hrs min.    Telcordia TR/SR-332 (Bellcore) ; 75.9K hrs min.    MIL-HDBK-217F (25°C)(-C) 690.3K hrs min.    Telcordia TR/SR-332 (Bellcore) ; 78.9K hrs min.    MIL-HDBK-217F (25°C)(-E)	
	DIMENSION	245*70*164.2mm (L*W*H)	483.6*66.3*132mm (L*W*H)
	PACKING	1.68Kg; 8pcs/14.4Kg/2.14CUFT	2.16Kg; 6pcs/14Kg/2.91CUFT
NOTE	<p>1. Data log and event log functions are only available when an SD card is installed.</p> <p>2. Depend on application.</p> <p>3. LCD may freeze under -20°C.</p> <p>4. CN36, CN37 are considered as O/P.</p> <p>5. All functions of signal connectors: DIN/DOUT, AIN/AOUT, Relay, RS-232, RS-485, PMBus, CANBus are defined by application. Please check installation manual for detail.</p> <p>6. The controller is considered a component which will be installed into a final equipment. EMC is tested by the controller unit, no control equipment is connected. The final equipment must re-confirmed that still meets EMC directives. For guidance on how to perform these EMC test, Please refer to "EMI testing of component power supplies". (as available on <a href="https://www.meanwell.com/Upload/PDF/EMI_statement_en.pdf">https://www.meanwell.com/Upload/PDF/EMI_statement_en.pdf</a>)</p> <p>7. The RTC power supply used super capacitors, which can last for only 7 days. If the time exceeds the limit, the RTC date must be re-adjusted.</p> <p>8. Up to 40 power supplies can be operate in parallel connection, and possible up to 48 power supplies.</p> <p>9. Order model only CMU2C-P##, CMU2C-R-P##, CMU2C-C##, CMU2C-R-C## and optional CMU2A-#R# available.</p> <p>※ Product Liability Disclaimer : For detailed information, please refer to <a href="https://www.meanwell.com/serviceDisclaimer.aspx">https://www.meanwell.com/serviceDisclaimer.aspx</a></p>		

■ Mechanical Specification (Single Unit)

(Unit: mm , tolerance  $\pm 1$ mm)

Case No. CUM2

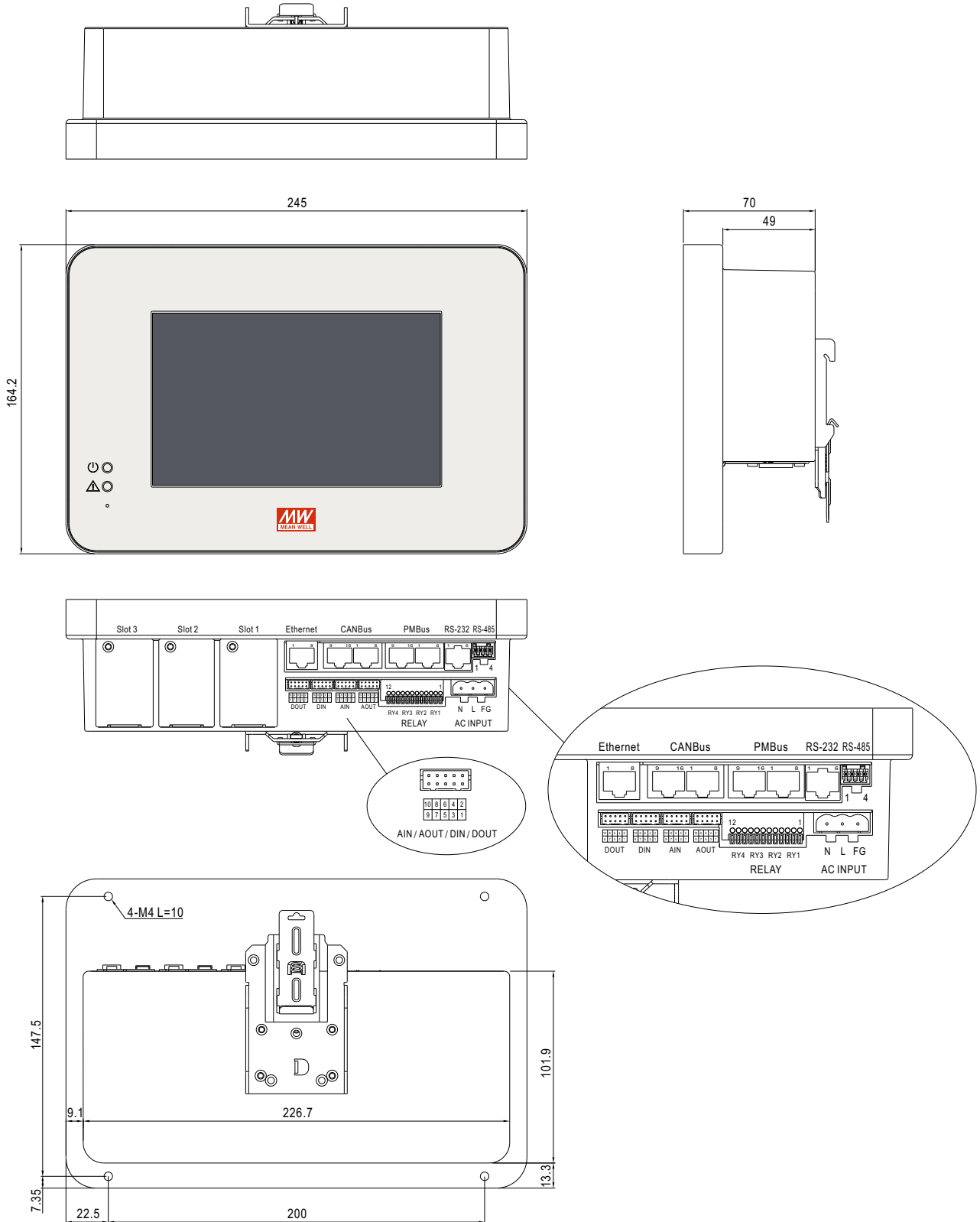

## Mechanical Specification (Rack System)

(Unit: mm , tolerance  $\pm 1$ mm)

Case No. CMU2-RACK

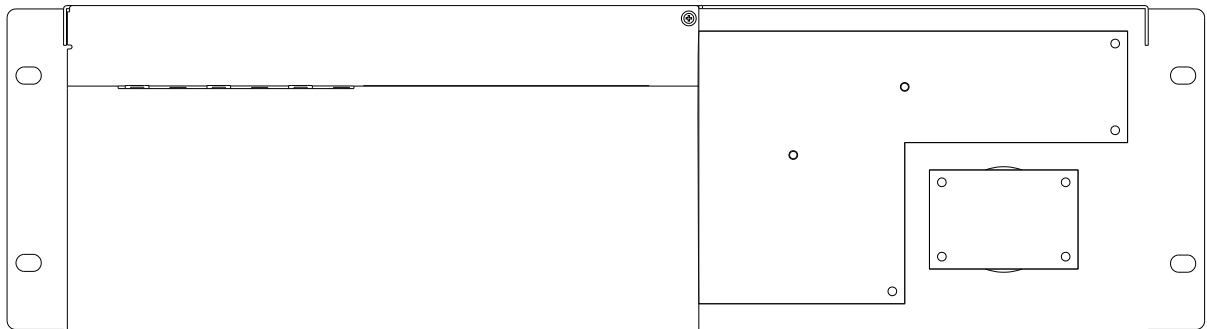
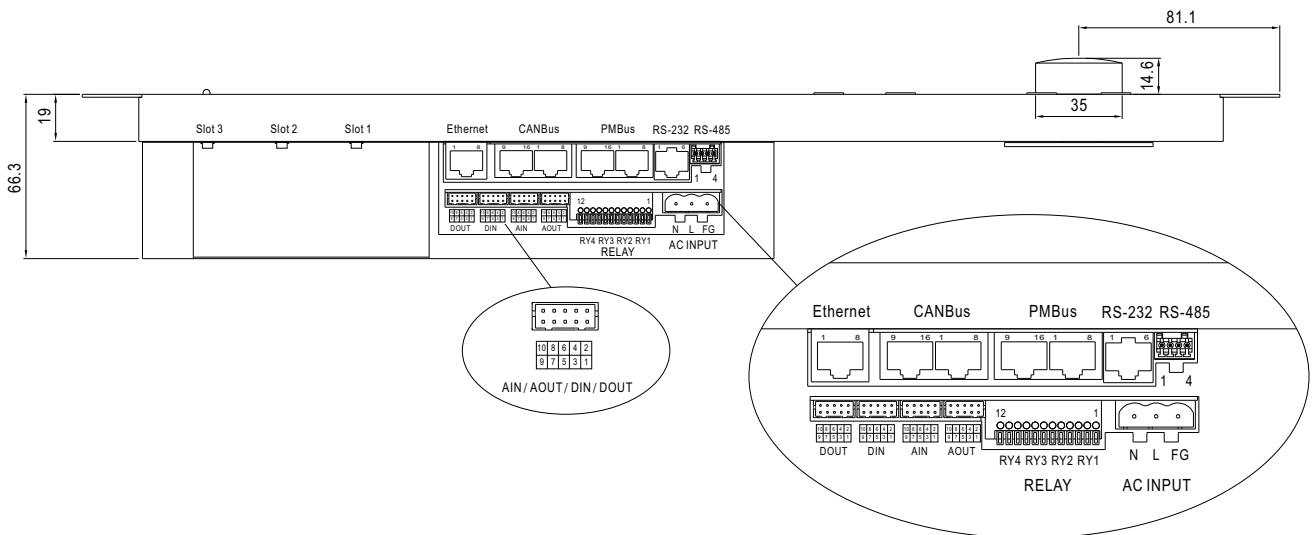
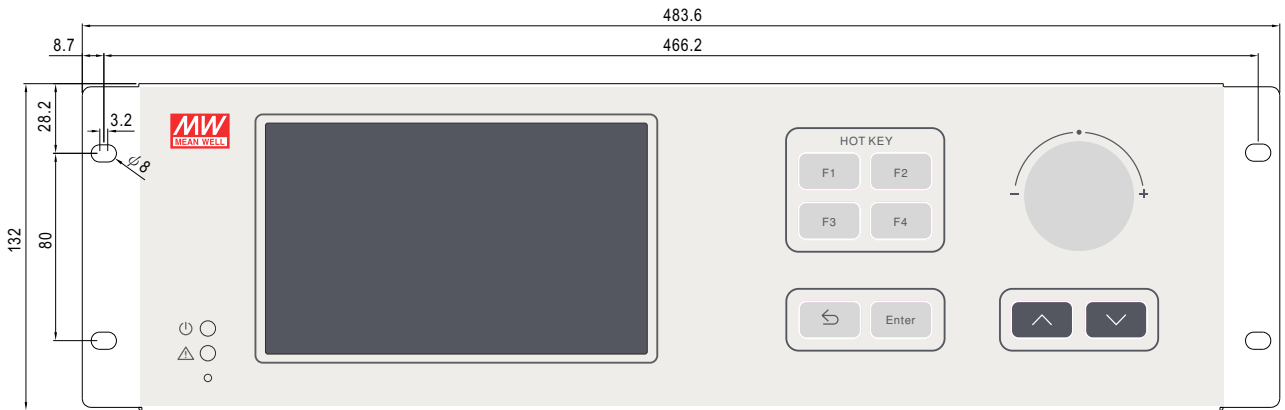

■ Mechanical Specification (Extension cards)

※ PMBus(P card)

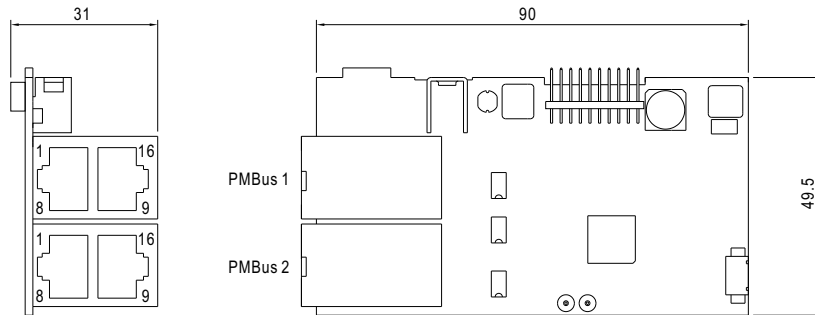

※ CANBus(C card)

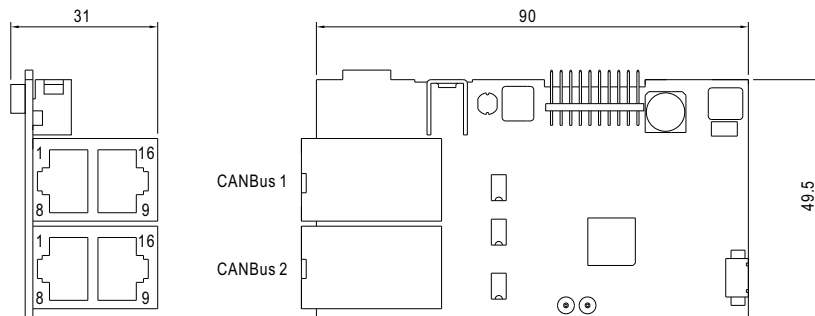

※ RS-232/RS485/USB(R card)

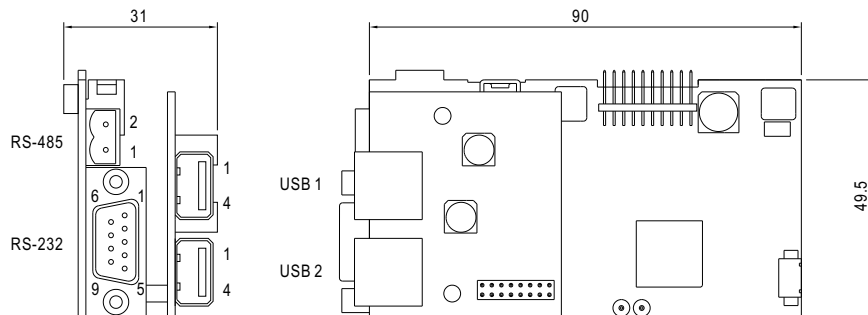

※ LED Status Indicators & Corresponding Signal at Function Pins

LED	Description
● Green	The power supply functions normally
● Red	The LED will present a constant red light when the abnormal status arises

※ AC IN Connector Pin No. Assignment (AC INPUT):

Pin No.	Function	Description
1	AC/N	AC input neutral wire
2	AC/L	AC input live wire
3	FG	FG wire

※ Relay Connector Pin No. Assignment (RELAY): DECA MX422-25412 or equivalent

Pin No.	Function	Description
1	RY1-NO	Normal-open contact of programmable relay1
2	RY1-NC	Normal-close contact of programmable relay1
3	RY1-COM	Common for relay1 NO/NC contact
4	RY2-NO	Normal-open contact of programmable relay2
5	RY2-NC	Normal-close contact of programmable relay2
6	RY2-COM	Common for relay2 NO/NC contact
7	RY3-NO	Normal-open contact of programmable relay3
8	RY3-NC	Normal-close contact of programmable relay3
9	RY3-COM	Common for relay3 NO/NC contact
10	RY4-NO	Normal-open contact of programmable relay4
11	RY4-NC	Normal-close contact of programmable relay4
12	RY4-COM	Common for relay4 NO/NC contact

※ AIN Connector Pin No. Assignment (AIN): HIROSE DF11-10 or equivalent

Pin No.	Function	Description
1	AIN 1	The Analog input signal with GND as reference
2,4,6,8,10	GND	Common GND for AINx
3	AIN 2	The Analog input signal with GND as reference
5	AIN 3	
7	AIN 4	
9	AIN 5	

※ AOUT Connector Pin No. Assignment (AOUT): HIROSE DF11-10 or equivalent

Pin No.	Function	Description
1	AOUT 1	The Analog output signal with GND as reference
2,4,6,8,10	GND	Common GND for AOUTx
3	AOUT 2	The Analog output signal with GND as reference
5	AOUT 3	
7	AOUT 4	
9	AOUT 5	

※ DOUT Connector Pin No. Assignment (DOUT): HIROSE DF11-10 or equivalent

Pin No.	Function	Description
1	DOUT 1	The isolated digital output signal with FG as reference Open collector signal, Max. signal voltage is 5V with FG as reference
2,4,6,8,10	FG	Common FG for DOUTx
3	DOUT 2	The isolated digital output signal with FG as reference Open collector signal, Max. signal voltage is 5V with FG as reference
5	DOUT 3	
7	DOUT 4	
9	DOUT 5	

※ DIN Connector Pin No. Assignment (DIN)

Pin No.	Function	Description
1	DIN 1	The isolated digital input signal with FG as reference Open from FG or +5V : Logic "1" input to CMU2 Short to FG or 0V : Logic "0" input to CMU2
2,4,6,8,10	FG	Common FG for DINx
3	DIN 2	The isolated digital input signal with FG as reference Open from FG or +5V : Logic "1" input to CMU2 Short to FG or 0V : Logic "0" input to CMU2
5	DIN 3	
7	DIN 4	
9	DIN 5	

※ RS-485 Connector Pin No. Assignment (RS-485) & Extension Cards(RS-485): DECA ME030-5802 or equivalent

Pin No.	Function	Description
1	D- / DB	Differential digital signal used in the RS485 interface
2	D+ /DA	Differential digital signal used in the RS485 interface
3,4	FG	Common FG for signal

※ RS-232 Connector Pin No. Assignment (RS-232): RJ11 6 position

Pin No.	Function	Description
1	+5V_AUX	VCC
2	RXD	Data receiving pin of RS-232 interface
3	FG	Common FG for signal
4	TXD	Data transmitting pin of RS-232 interface
5,6	NC	Not used

※ PMBus Connector Pin No. Assignment (PMBus) & Extension Cards(PMBus (PMBus 1,PMBus 2)): RJ45 8 positions

Pin No.	Function	Description
1,2,3,5,9,10,11,13	NC	Not use
4,12	CONTROL	Remote ON/OFF control pin (Note)
6,14	SDA	Serial Data used in the PMBus interface (Note)
7,15	SCL	Serial Clock used in the PMBus interface (Note)
8,16	FG	Common FG for signal

Note: Isolated signal, with FG as reference

※ CANBus Connector Pin No. Assignment (CANBus) & Extension Cards(CANBus (CANBus 1,CANBus 2)): RJ45 8 positions

Pin No.	Function	Description
1,2,3,5,9,10,11,13	NC	Not use
4,12	CONTROL	Remote ON/OFF control pin (Note)
6,14	CAN-H	CAN-H used in the CAN Bus interface (Note)
7,15	CAN-L	CAN-L used in the CAN Bus interface (Note)
8,16	FG	Common FG for signal

Note: Isolated signal, with FG as reference

※ Ethernet Connector Pin No. Assignment (Ethernet): RJ45 8 position

Pin No.	Function	Description
1	TX+	Transmit data used in the Ethernet interface
2	TX-	
3	RX+	Receive data used in the Ethernet interface
4,5,7,8	FG	Common FG for signal
6	RX-	Receive data used in the Ethernet interface

※ Extension Cards(RS-232)

Pin No.	Function	Description
1,4,6,7,8,9	NC	Not used
2	RXD	Data receiving pin of RS-232 interface
3	TXD	Data transmitting pin of RS-232 interface
4	GND-FG	RS-232 common GND. This signal connects to FG and isolated from -V and GND-AUX

※ Extension Cards(USB1,USB2): USB A Type

Pin No.	Function	Description
1	+5V_AUX	VCC / max. 0.5A
2	D-	Data-
3	D+	Data+
4	FG	Common FG for signal

■ Table for functionality of connectors

Model	Relay	RS485	AIN	AOUT	DIN	DOUT	PMBus	CANBus	RS-232	Ethernet
CMU2A-#R# (Optional)	√	X	X	X	X	X	X	√	X	√
CMU2C-P##	√	X	X	X	√	√	√	X	X	√
CMU2C-R-P##	√	X	X	X	√	√	√	X	X	√
CMU2C-C##	√	X	X	X	√	√	X	√	X	√
CMU2C-R-C##	√	X	X	X	√	√	X	√	X	√
CMU2E-###	√	√	X	X	√	√	X	√	X	√
CMU2E-R-###	√	√	X	X	√	√	X	√	X	√

√: Functional

X: Not functional

■ Table for supported models

Model	Supported series
CMU2A-#R# (Optional)	ERS-5000(H), ERG-5000(H)
CMU2C-P## CMU2C-R-P##	DRP-3200, NCP-3200, PHP-3500, RCP-2000, RCP-1600, HEP-1000
CMU2C-C## CMU2C-R-C##	DRP-3200CAN, NCP-3200CAN, SHP-30KCAN, SHP-10KCAN, BIC-2200, HEP-2300
CMU2E-### CMU2E-R-###	NTN-5K

Note: For models not listed, please contact MEAN WELL

■ Installation Instruction

① Din Rail

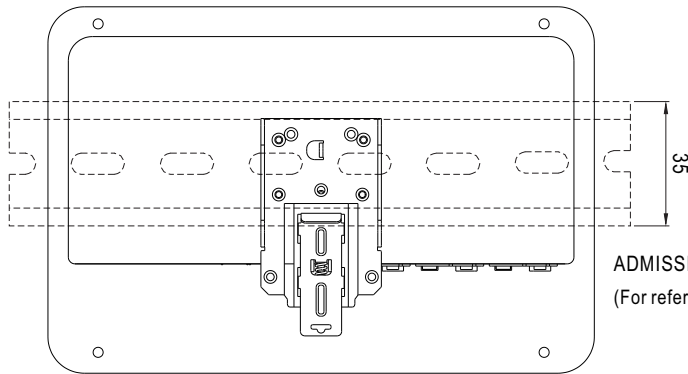

This series fits DIN rail TS35/7.5 or TS35/15.  
For installation details, please refer to the Instruction manual.

ADMISSIBLE DIN-RAIL: TS35/7.5 OR TS35/15  
(For reference only. Not included with unit.)

Back View

② Wallhanging

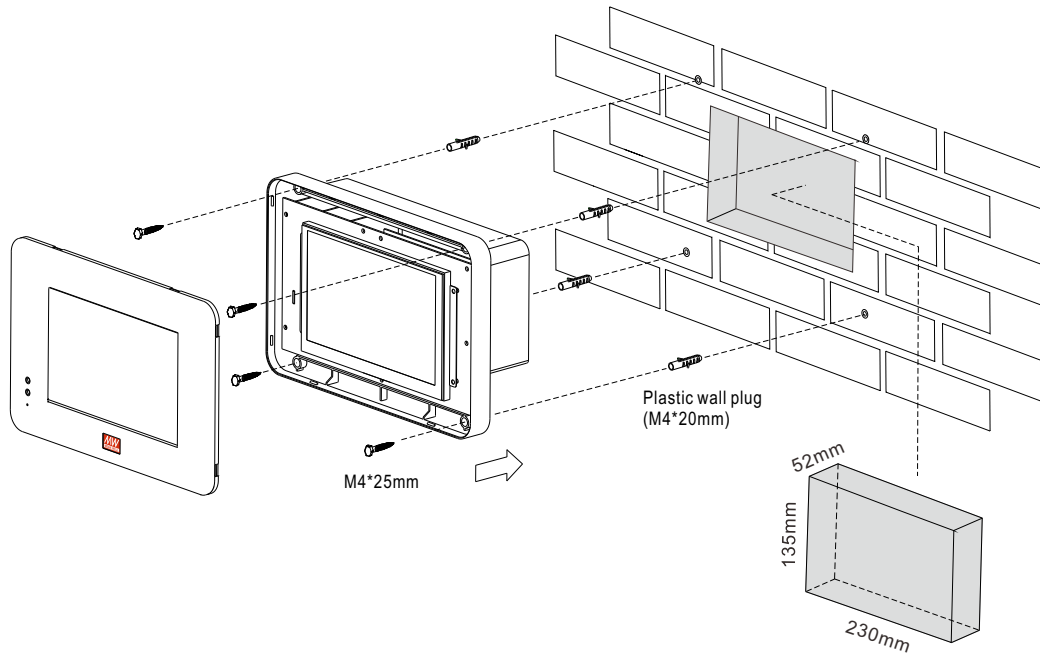

③ Desktop

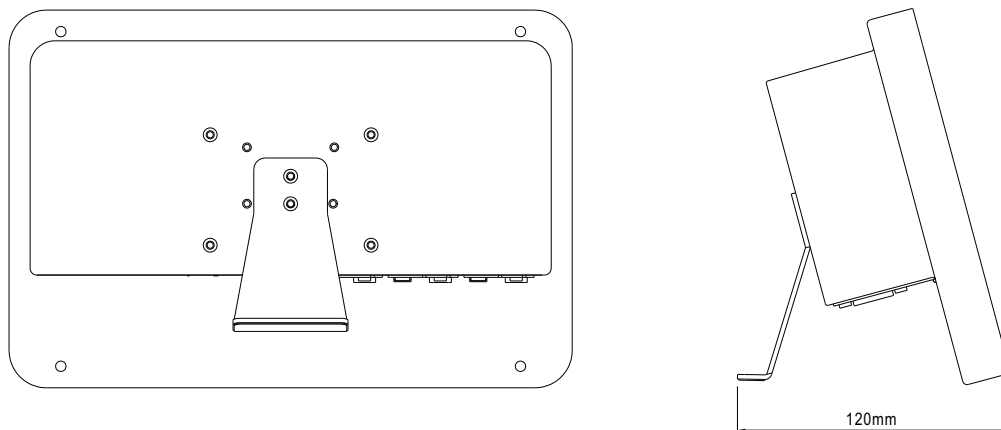

■ Accessory List

Accessories are included in corresponding models

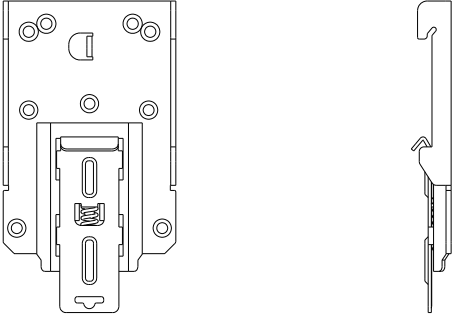
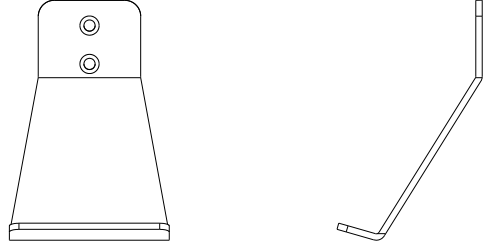
<p>①</p>	<p>1GG2DRP14A</p>	
<p>②</p>	<p>1GG2MHS094</p>	

## ■ TYPICAL APPLICATION

### Application of Power Management



**CMU2**

- System status monitoring
- Local and remote control
- Programmable voltage
- Programmable current
- Event & data log

### Application of Burn-in System

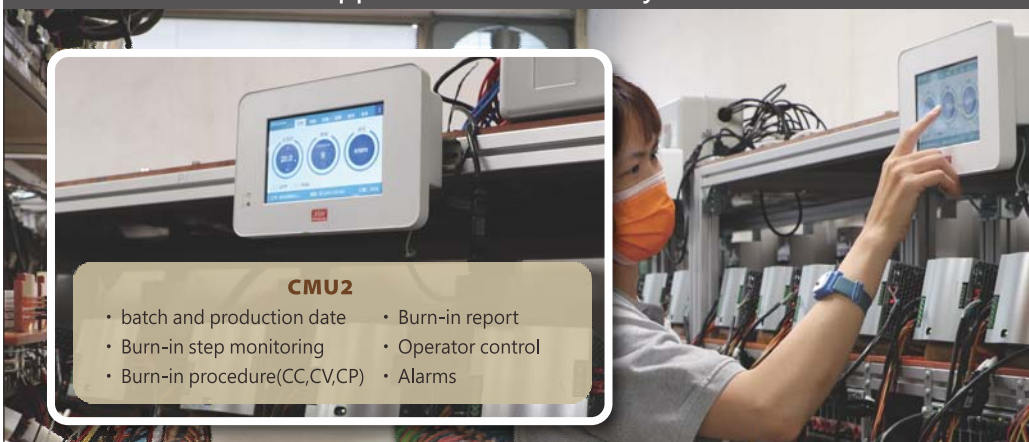

**CMU2**

- batch and production date
- Burn-in step monitoring
- Burn-in procedure(CC,CV,CP)
- Burn-in report
- Operator control
- Alarms