



Test Report: NSP-1000-48

1000W AC/DC High Reliable Multi-Industrial Enclosed Type Power Supply

■ DESIGN VERIFY TEST

Output Function Test

Input Function Test

Protection Function Test

Control Function Test

Component Stress Test

■ SAFETY & E.M.C. TEST

Safety Test

E.M.C. Test

■ RELIABILITY TEST

ENVIRONMENT TEST

■ DESIGN VERIFY TEST

OUTPUT FUNCTION TEST

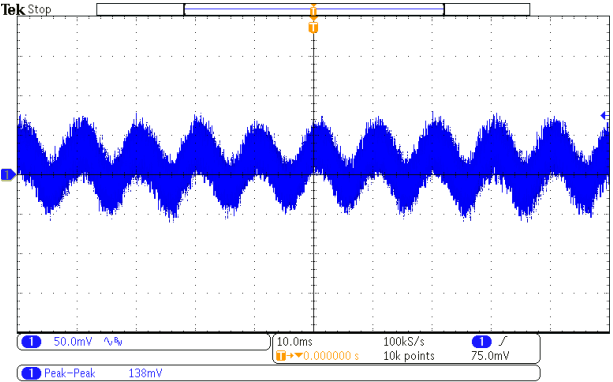
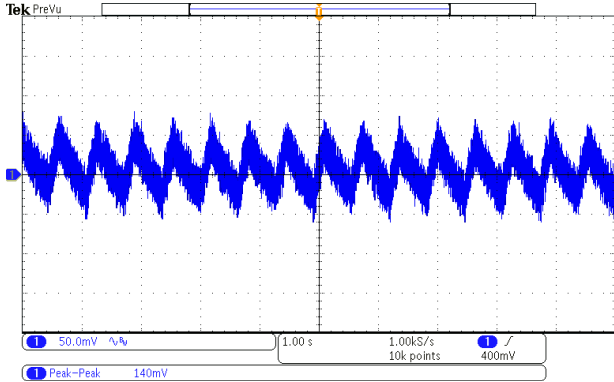
NO	TEST ITEM	SPECIFICATION	TEST CONDITION	RESULT
1	OUTPUT VOLTAGE ADJUST RANGE	CH1: 43.2V~55V	I/P : 230 VAC O/P : MIN LOAD Ta : 25°C	40.86V~57.86V/230VAC
2	OUTPUT VOLTAGE TOLERANCE	V1: -1%~ 1%	I/P: 85VAC /305VAC O/P:FULL/ MIN. LOAD Ta:25°C	V1: 0.4%~ 0.6%
3	LINE REGULATION	V1: -0.5%~ 0.5%	I/P: 85VAC~ 305VAC O/P:FULL LOAD Ta:25°C	V1: -0.1%~0.12%
4	LOAD REGULATION	V1: -0.5%~ 0.5%	I/P: 230VAC O/P:FULL ~MIN LOAD Ta:25°C	V1: 0.1%~ 0.25 %
5	OVER/UNDERSHOOT TEST	< ± 5%	I/P: 230VAC O/P:FULL LOAD Ta:25°C	3.2%
6	RIPPLE & NOISE (Max)	V1:300mVp-p	I/P: 230 VAC O/P: MIN LOAD—FULL LOAD Ta:25°C	V1: 140mVp-p / 100% load
		<div style="display: flex; justify-content: space-around;"> <div style="text-align: center;"> <p>high frequency :</p>  <p>50.0mV/div, 10.0ms/div, Peak-Peak 138mV</p> </div> <div style="text-align: center;"> <p>low frequency :</p>  <p>50.0mV/div, 1.00s/div, Peak-Peak 140mV</p> </div> </div>		
7	SET UP TIME(Max)	277VAC/1500ms 230VAC/1500ms 115VAC/2500ms	I/P : 277VAC I/P : 230VAC I/P : 115VAC O/P : FULL LOAD Ta : 25°C	277VAC/ 988ms 230VAC/ 1198ms 115VAC/ 1950ms

INPUT=277VAC/60HZ @ FULL LOAD
CH1 : Output Voltage CH2 : AC Input Voltage

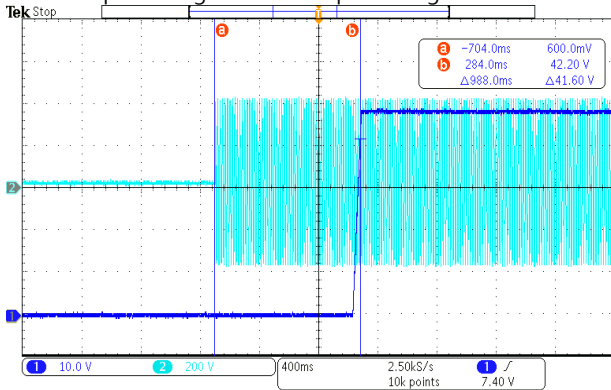

INPUT=230VAC/50HZ @ FULL LOAD
CH1 : Output Voltage CH2 : AC Input Voltage

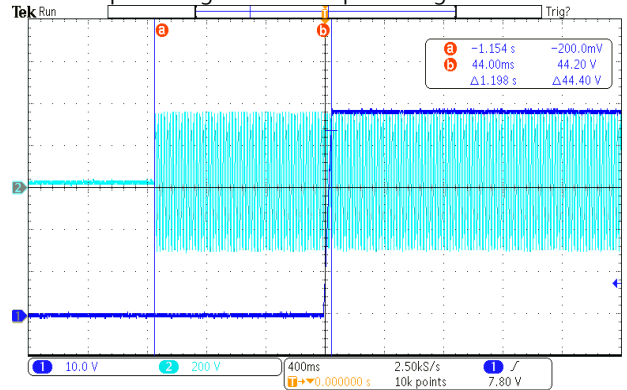

INPUT=115VAC/60HZ @ FULL LOAD
CH1 : Output Voltage CH2 : AC Input Voltage

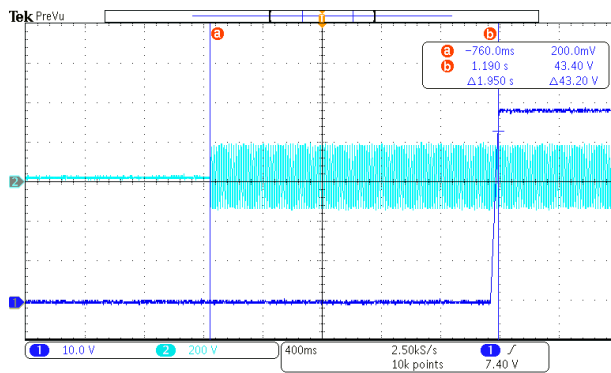

8 RISE TIME (Max)

277VAC/80ms
230VAC/80ms
115VAC/80ms

I/P : 277VAC
I/P : 230VAC
I/P : 115VAC
O/P : FULL LOAD
Ta : 25°C

277VAC/ 47ms
230VAC/ 47ms
115VAC/ 46ms

INPUT=277VAC/60HZ @ FULL LOAD
CH1 : Output Voltage

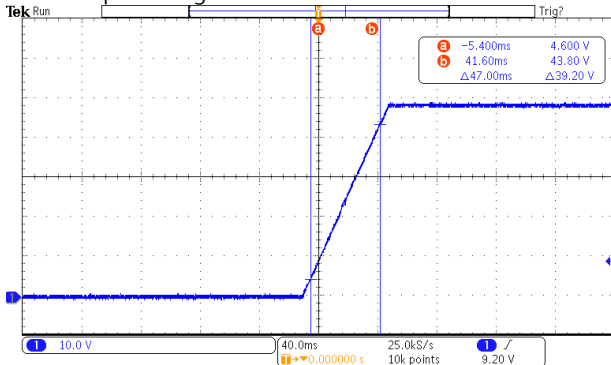

INPUT=230VAC/50HZ @ FULL LOAD
CH1 : Output Voltage

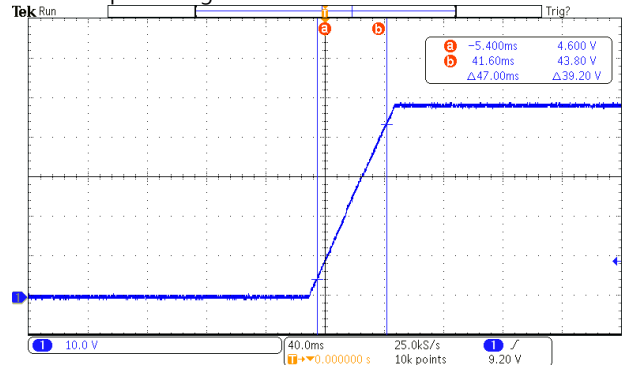

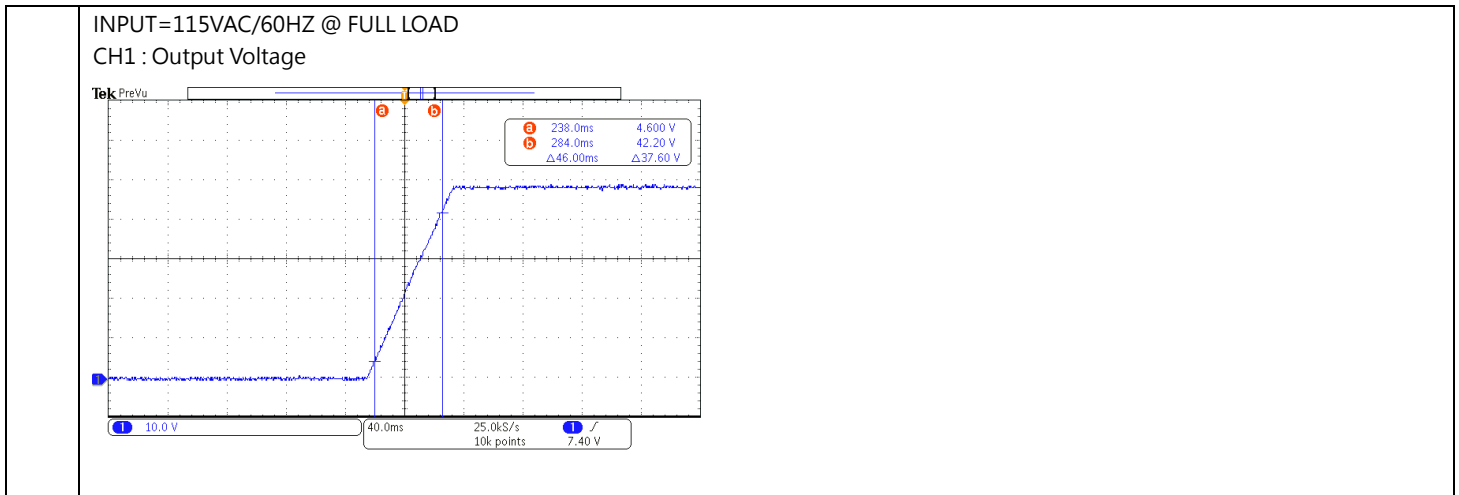

9	HOLD UP TIME (Typ.)	12ms@70%load	I/P : 277 VAC	FULL LOAD
		8ms@full load	I/P : 230VAC	277VAC: 21.8ms
			I/P : 115 VAC	230VAC: 21.4ms
			O/P : 70%LOAD/FULL LOAD	115VAC: 21ms
			Ta : 25°C	
				70% LOAD
				277VAC: 31ms
				230VAC: 29.5ms
				115VAC: 31ms

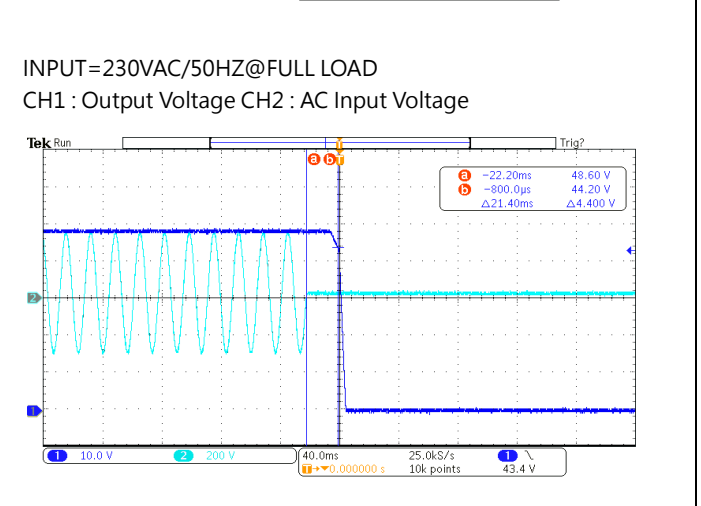
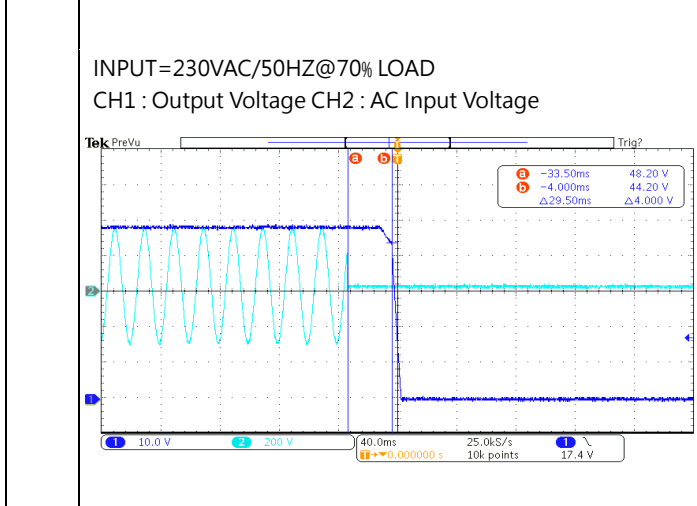
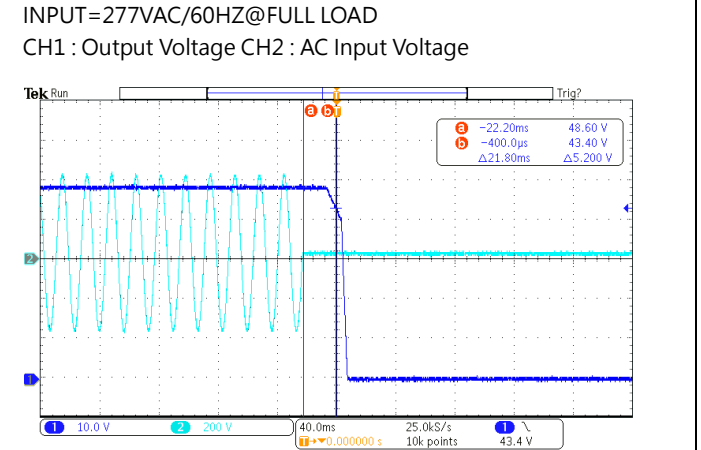
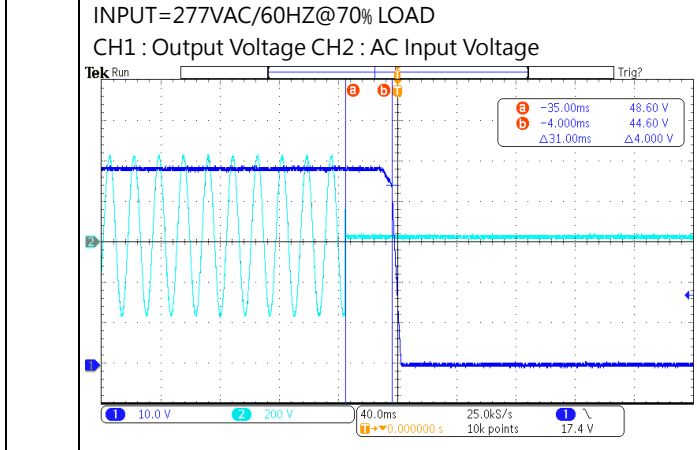

	<p>INPUT=115VAC/60HZ@70% LOAD CH1 : Output Voltage CH2 : AC Input Voltage</p>		<p>INPUT=115VAC/60HZ@FULL LOAD CH1 : Output Voltage CH2 : AC Input Voltage</p>	
10	DYNAMIC LOAD	V1: 9600mVp-p	<p>I/P: 230VAC O/P: (1)FULL /50% LOAD 50%DUTY / 120HZ (2)FULL /50% LOAD 50%DUTY / 1KHZ Ta:25°C</p>	<p>4520mVp-p 1040mVp-p</p>
	<p>FULL /50% LOAD 50%DUTY / 120HZ</p>		<p>FULL /50% LOAD 50%DUTY / 1KHZ</p>	

INPUT FUNCTION TEST

NO	TEST ITEM	SPECIFICATION	TEST CONDITION	RESULT
1	INPUT VOLTAGE RANGE	85VAC~305VAC 120VDC~ 431VDC	(1) I/P:TESTING O/P:FULL LOAD (2) I/P:DC TESTING(L:+ N:-) O/P: FULL / 50% LOAD (3) I/P:DC TESTING(L:- N:+) O/P: FULL / 50% LOAD Ta:25°C	(1)72V~308VAC (2) 120Vdc~431Vdc/FULL LOAD 120Vdc~431Vdc/50% LOAD (3) 120Vdc~431Vdc/FULL LOAD 120Vdc~431 Vdc/50% LOAD
			I/P: LOW-LINE-3V=82V HIGH-LINE+10V=315 V O/P:FULL/MIN LOAD (PLEASE CHECK DERATING CURVE) ON: 30 Sec OFF: 30 Sec 10MIN (POWER ON/OFF NO DAMAGE)	TEST:PASS
2	INPUT FREQUENCY RANGE	47HZ ~63 HZ NO DAMAGE	I/P:85VAC ~264 VAC O/P:FULL~MIN LOAD Ta:25°C	TEST: PASS
3	INPUT CURRENT (Typ.)	277V/ 5A 230V/ 6A 115V/ 12A	I/P : 277VAC I/P : 230VAC I/P : 115VAC O/P : FULL LOAD Ta : 25°C	I =4.0A/ 277VAC I =4.8A/ 230VAC I =9.8A/ 115VAC
4	LEAKAGE CURRENT	Earth leakage current < 350μA(rms)@277VAC	I/P : 277 VAC O/P : Min LOAD Ta : 25°C	L-FG : 230.2 μA N-FG : 229.6 μA
		Touch current <100μA (rms)@277 VAC		L-V+ : 72.4 μA L-V- : 73.2 μA N-V+ : 73.4 μA N-V- : 73.4 μA
5	POWER FACTOR (Typ.)	0.92/277VAC 0.95/ 230VAC 0.98/ 115VAC	I/P : 277VAC I/P : 230VAC I/P : 115VAC O/P : FULL LOAD Ta : 25°C	PF=0.965/277VAC PF=0.984/230VAC PF=0.994/115VAC

P.F vs LOAD

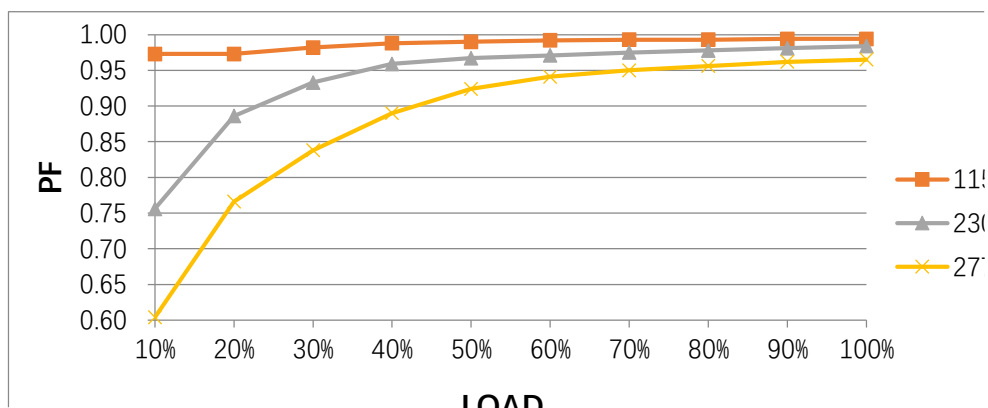



6	EFFICIENCY(Typ.)	94%	I/P:230 VAC O/P:FULL LOAD Ta:25°C	94.5%																																												
<p>EFFICIENCY vs LOAD</p> <table border="1"> <caption>Efficiency vs Load Data</caption> <thead> <tr> <th>LOAD (%)</th> <th>115VAC (%)</th> <th>230VAC (%)</th> <th>277VAC (%)</th> </tr> </thead> <tbody> <tr><td>10%</td><td>80</td><td>80</td><td>80</td></tr> <tr><td>20%</td><td>85</td><td>85</td><td>85</td></tr> <tr><td>30%</td><td>90</td><td>90</td><td>90</td></tr> <tr><td>40%</td><td>91</td><td>91</td><td>91</td></tr> <tr><td>50%</td><td>92</td><td>92</td><td>92</td></tr> <tr><td>60%</td><td>92</td><td>92</td><td>92</td></tr> <tr><td>70%</td><td>92</td><td>92</td><td>92</td></tr> <tr><td>80%</td><td>92</td><td>92</td><td>92</td></tr> <tr><td>90%</td><td>92</td><td>92</td><td>92</td></tr> <tr><td>100%</td><td>92</td><td>92</td><td>92</td></tr> </tbody> </table>					LOAD (%)	115VAC (%)	230VAC (%)	277VAC (%)	10%	80	80	80	20%	85	85	85	30%	90	90	90	40%	91	91	91	50%	92	92	92	60%	92	92	92	70%	92	92	92	80%	92	92	92	90%	92	92	92	100%	92	92	92
LOAD (%)	115VAC (%)	230VAC (%)	277VAC (%)																																													
10%	80	80	80																																													
20%	85	85	85																																													
30%	90	90	90																																													
40%	91	91	91																																													
50%	92	92	92																																													
60%	92	92	92																																													
70%	92	92	92																																													
80%	92	92	92																																													
90%	92	92	92																																													
100%	92	92	92																																													
7	INRUSH CURRENT(Typ.)	50A/277VAC 40A/230VAC 25A/115VAC COLD START	I/P : 277VAC I/P : 230VAC I/P : 115VAC O/P : FULL LOAD Ta : 25°C	I =46.5A/ 277VAC T50=1950us/277V I =27.4A/230VAC T50=1775us/230V I =12.9A/ 115VAC T50=2325us/115V																																												
<div style="display: flex; justify-content: space-around;"> <div data-bbox="151 1131 790 1590"> <p>INPUT=277VAC/50HZ @ FULL LOAD CH2 : AC Input Voltage CH4 : Input current</p> <p>Max: 46.5 A</p> </div> <div data-bbox="805 1131 1524 1590"> <p>INPUT=230VAC/50HZ @ FULL LOAD CH2 : AC Input Voltage CH4 : Input current</p> <p>Max: 27.4 A</p> </div> </div> <div style="display: flex; justify-content: space-around; margin-top: 20px;"> <div data-bbox="151 1590 790 2072"> <p>INPUT=115VAC/50HZ @ FULL LOAD CH2 : AC Input Voltage CH4: Input current</p> <p>Max: 12.9 A</p> </div> </div>																																																

PROTECTION FUNCTION TEST





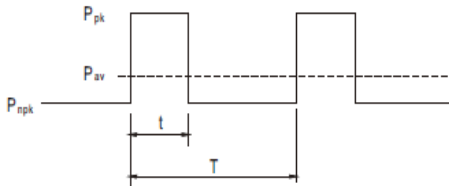
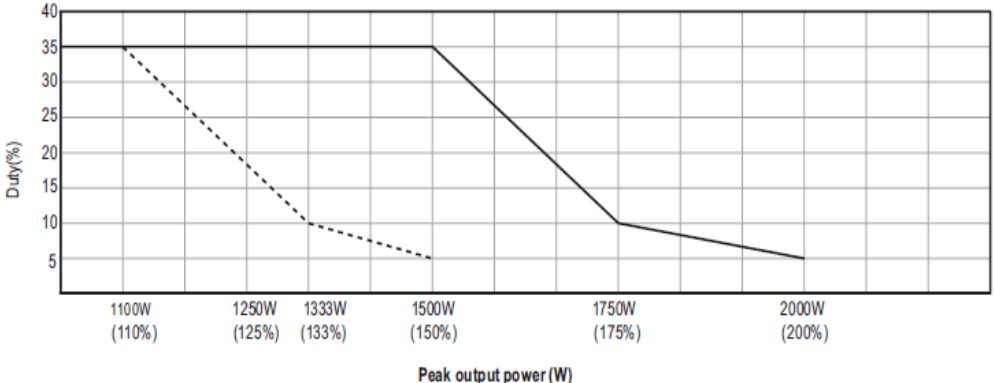

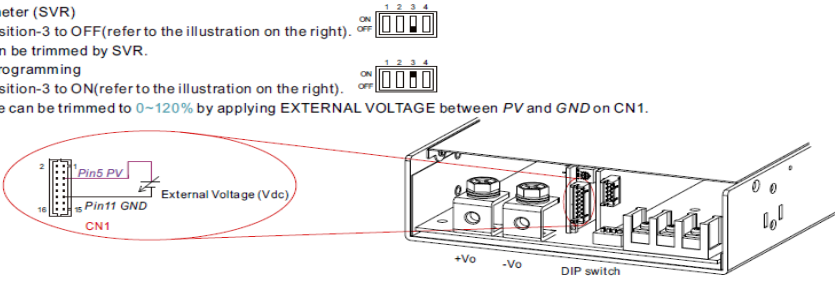
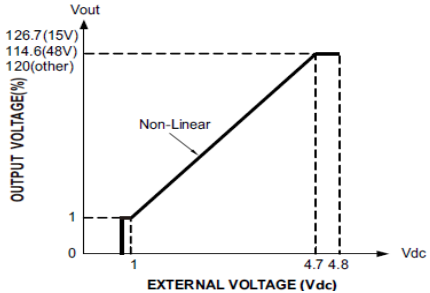
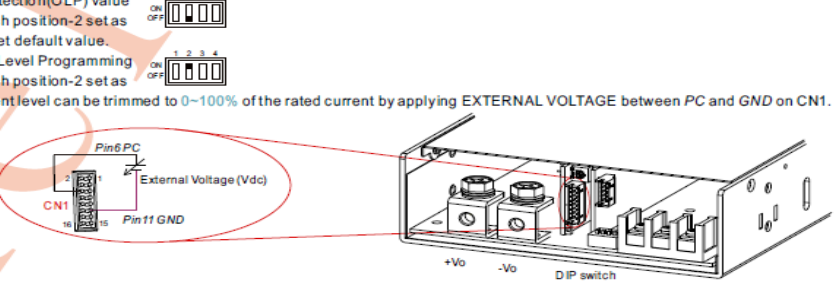
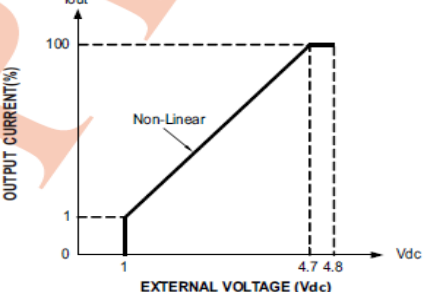

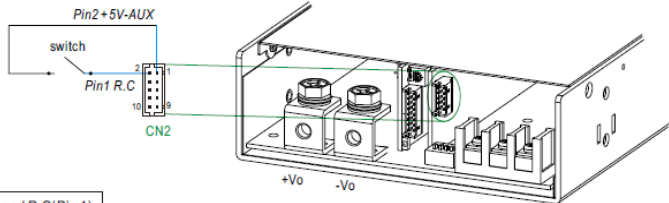
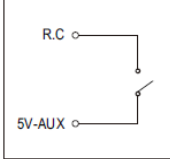
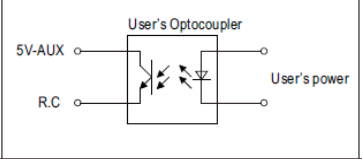
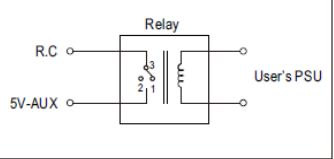
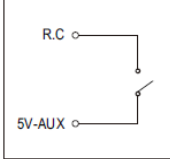
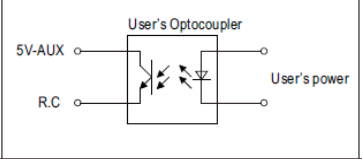
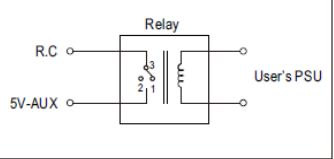
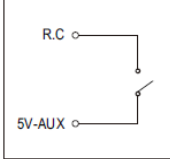
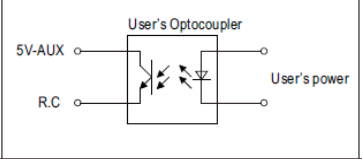
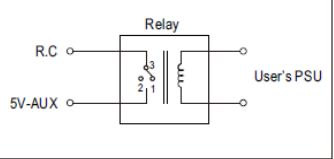







































NO	TEST ITEM	SPECIFICATION	TEST CONDITION	RESULT
1	OVER LOAD PROTECTION	105 % ~ 200 %	I/P: 305VAC I/P: 230VAC I/P: 85VAC O/P:TESTING Ta:25°C	112%/ 305VAC 112%/ 230VAC 112%/85VAC Protection type : Peak Load Mode: From 105% to 200% of rated output power, unit will shut down after 5 seconds of continuous operation. AC repower on to recover. At >200% of rated output power, constant current limiting is activated. Unit will shut down after 5 seconds of continuous operation. AC repower on to recover. Current Limiting Mode: Constant current limiting, recovers automatically after abnormal condition is removed.
2	OVER VOLTAGE PROTECTION	56V~63V	I/P: 305VAC I/P: 230VAC I/P: 85VAC O/P:MIN LOAD Ta:25°C	58.7V/ 305VAC 58.7V/ 230VAC 58.7V/ 85VAC Protection type : Shut down and latch off output voltage, re-power on to recover
3	OVER TEMPERATURE PROTECTION	NO DAMAGE	I/P: 305VAC I/P: 85VAC O/P:FULL LOAD	O.T.P. Active Protection type : Shut down output voltage, recovers automatically after temperature goes down
4	SHORT PROTECTION	SHORT EVERY OUTPUT 1 HOUR NO DAMAGE	I/P: 305VAC I/P: 85VAC O/P: FULL LOAD Ta:25°C	NO DAMAGE Protection type : Peak Load Mode: Constant current limiting, unit will shut down after 5 Sec, AC repower on to recover. Current Limiting Mode: Constant current limiting, recovers automatically after abnormal condition is removed.

CONTROL FUNCTION TEST

NO	TEST ITEM	SPECIFICATION	TEST CONDITION	RESULT
1	PEAK POWER	<p>■ Function Manual</p> <p>1. Peak Power</p> $P_{av} = \frac{P_{pk} \times t + P_{rpik} \times (T-t)}{T} \leq P_{rated}$ $Duty = \frac{t}{T} \times 100\% \leq 35\%$ $t \leq 5 \text{ sec}$  <p> P_{pk}: Peak output power (W) P_{rpik}: Non-peak output power (W) P_{rated}: Rated output power (W) t: Peak power width(sec) T: Period(sec) </p>  <p> For example (24V model) $V_{in}=220Vac, Duty_max=5\%$ $P_{av}=P_{rated}=1000W$ $P_{pk}=2000W$ $t \leq 5sec$ $T \geq \frac{5sec}{5\%} = 100sec$ $P_{rpik} \leq \frac{TP_{av}-tP_{pk}}{T-t} = 947.4W$ </p> <p>Note: When the output voltage is adjusted to the upper limit, the peak power is 150% of rated power</p>		<p>I/P: 100/200 VAC O/P: PEAK LOAD Ta: 25°C TEST RESULT : PASS</p>

<p>2</p> <p>OUTPUT VOLTAGE PROGRAMMABLE(PV)</p>		<p>2. Output Voltage Programming (P.V)</p> <p>(1) Default by potentiometer (SVR) (a) Set DIP switch position-3 to OFF (refer to the illustration on the right). (b) Output voltage can be trimmed by SVR.</p> <p>(2) By Output Voltage Programming (a) Set DIP switch position-3 to ON (refer to the illustration on the right). (b) The output voltage can be trimmed to 0~120% by applying EXTERNAL VOLTAGE between PV and GND on CN1.</p>   <p>I/P: 230 VAC O/P: FULL LOAD Ta: 25°C TEST RESULT :</p> <table border="1" data-bbox="502 974 1540 1153"> <thead> <tr> <th>External voltage(DC)</th> <th><0.4V</th> <th>1V</th> <th>2.596V</th> <th>4.7V</th> <th>4.8V</th> </tr> </thead> <tbody> <tr> <td>SPEC(%)</td> <td>0%</td> <td>0%~6%</td> <td>50%±5%</td> <td>114.6%±5%</td> <td>114.6%±5%</td> </tr> <tr> <td>Vout(%)</td> <td>0%</td> <td>0.461V(0.96%)</td> <td>23.65V(49.27%)</td> <td>54.16V(112.84%)</td> <td>55.5V(115.63%)</td> </tr> </tbody> </table>	External voltage(DC)	<0.4V	1V	2.596V	4.7V	4.8V	SPEC(%)	0%	0%~6%	50%±5%	114.6%±5%	114.6%±5%	Vout(%)	0%	0.461V(0.96%)	23.65V(49.27%)	54.16V(112.84%)	55.5V(115.63%)
External voltage(DC)	<0.4V	1V	2.596V	4.7V	4.8V															
SPEC(%)	0%	0%~6%	50%±5%	114.6%±5%	114.6%±5%															
Vout(%)	0%	0.461V(0.96%)	23.65V(49.27%)	54.16V(112.84%)	55.5V(115.63%)															
<p>3</p> <p>OUTPUT CURRENT PROGRAMMABLE (PC)</p>		<p>3. Output Current Programming (P.C)</p> <p>(1) Default Overload Protection (OLP) value (a) Have the DIP switch position-2 set as (b) Output current is set default value.</p> <p>(2) By Constant Current Level Programming (a) Have the DIP switch position-2 set as (b) The constant current level can be trimmed to 0~100% of the rated current by applying EXTERNAL VOLTAGE between PC and GND on CN1.</p>   <p>I/P: 230 VAC O/P: TESTING Ta: 25°C</p> <table border="1" data-bbox="502 1881 1540 2027"> <thead> <tr> <th>External voltage(DC)</th> <th><0.4V</th> <th>1V</th> <th>2.831V</th> <th>4.7V</th> <th>4.8V</th> </tr> </thead> <tbody> <tr> <td>SPEC(%)</td> <td>0%</td> <td>0%~6%</td> <td>50%±5%</td> <td>100%±5%</td> <td>100%±5%</td> </tr> <tr> <td>Iout(%)</td> <td>0%</td> <td>3%</td> <td>49.79%</td> <td>99.52%</td> <td>101.19%</td> </tr> </tbody> </table>	External voltage(DC)	<0.4V	1V	2.831V	4.7V	4.8V	SPEC(%)	0%	0%~6%	50%±5%	100%±5%	100%±5%	Iout(%)	0%	3%	49.79%	99.52%	101.19%
External voltage(DC)	<0.4V	1V	2.831V	4.7V	4.8V															
SPEC(%)	0%	0%~6%	50%±5%	100%±5%	100%±5%															
Iout(%)	0%	3%	49.79%	99.52%	101.19%															

<p>4</p>	<p>REMOTE CONTROL</p>	<p>4.Remote Control</p> <p>※ The power supply can be turned ON/OFF individually or along with other units by using the "Remote Control" function with external switch, potocoupler or relay.</p>  <table border="1" data-bbox="529 548 970 645"> <tr> <td>PSU Vo Status</td> <td>Between +5V-AUX(Pin 2) and R.C(Pin 1)</td> </tr> <tr> <td>Power ON</td> <td>Switch Short</td> </tr> <tr> <td>Power OFF</td> <td>Switch Open</td> </tr> </table> <table border="1" data-bbox="529 667 1396 896"> <tr> <td data-bbox="529 667 699 840">  </td> <td data-bbox="699 667 1061 840">  </td> <td data-bbox="1061 667 1396 840">  </td> </tr> <tr> <td>R.C. by external switch.</td> <td>R.C. by user's optocoupler control module.</td> <td>R.C. by user's Relay control module.</td> </tr> </table> <p>I/P: 230 VAC O/P:FULL LOAD Ta:25°C Test Result :</p> <table border="1" data-bbox="502 1041 1228 1160"> <tr> <td>Between +5V-AUX(Pin2) and R.C(Pin1)</td> <td>Power Supply Status</td> </tr> <tr> <td>SW SHORT</td> <td>ON</td> </tr> <tr> <td>SW OPEN</td> <td>OFF</td> </tr> </table>		PSU Vo Status	Between +5V-AUX(Pin 2) and R.C(Pin 1)	Power ON	Switch Short	Power OFF	Switch Open				R.C. by external switch.	R.C. by user's optocoupler control module.	R.C. by user's Relay control module.	Between +5V-AUX(Pin2) and R.C(Pin1)	Power Supply Status	SW SHORT	ON	SW OPEN	OFF
PSU Vo Status	Between +5V-AUX(Pin 2) and R.C(Pin 1)																				
Power ON	Switch Short																				
Power OFF	Switch Open																				
																					
R.C. by external switch.	R.C. by user's optocoupler control module.	R.C. by user's Relay control module.																			
Between +5V-AUX(Pin2) and R.C(Pin1)	Power Supply Status																				
SW SHORT	ON																				
SW OPEN	OFF																				
<p>5</p>	<p>REMOTE SENSE</p>	<p>S+ / S->0.5V Compensate voltage drop on the load wiring up to 0.5V.</p>	<p>I/P: 230 VAC O/P:FULL LOAD Ta:25°C</p> <p>> 0.5V</p>																		
<p>6</p>	<p>AUXILIARY POWER</p>	<p>1.Auxiliary voltage output, 10.2~13.8V, referenced to GND-AUX (pin2). The maximum load current is 0.8A. This output has the built-in "Oring diodes" and is not controlled by "Remote ON-OFF".</p> <p>2.Auxiliary voltage output, 4.25~5.75v, referenced to GND-AUX (pin2). The maximum load current is 0.3A. This output has the built-in "Oring diodes" and is not controlled by "Remote ON-OFF"</p> <p>I/P: 230 VAC O/P:FULL LOAD Ta:25°C Test Result :</p> <table border="1" data-bbox="587 1668 1428 1814"> <tr> <th>AUX</th> <th>TOLERANCE</th> <th>RIPPLE</th> <th>TEST RESULT</th> </tr> <tr> <td>12V / 0.8A</td> <td>10.2~13.8 V</td> <td>150mVp-p</td> <td>11.92V/ 113mVp-p</td> </tr> <tr> <td>5V / 0.2A</td> <td>4.25~5.75 V</td> <td>450mVp-p</td> <td>4.83V/114 mVp-p</td> </tr> </table>		AUX	TOLERANCE	RIPPLE	TEST RESULT	12V / 0.8A	10.2~13.8 V	150mVp-p	11.92V/ 113mVp-p	5V / 0.2A	4.25~5.75 V	450mVp-p	4.83V/114 mVp-p						
AUX	TOLERANCE	RIPPLE	TEST RESULT																		
12V / 0.8A	10.2~13.8 V	150mVp-p	11.92V/ 113mVp-p																		
5V / 0.2A	4.25~5.75 V	450mVp-p	4.83V/114 mVp-p																		
<p>7</p>	<p>DC OK SIGNAL</p>	<p>I/P:230VAC O/P: FULL LOAD Ta:25°C TEST: OK</p>																			

8	LED Status indicators	<p>※ LED Status Indicators</p> <table border="1" data-bbox="507 300 1538 1077"> <thead> <tr> <th data-bbox="507 300 978 342">Description</th> <th colspan="3" data-bbox="978 300 1538 342">Output of alarm</th> </tr> </thead> <tbody> <tr> <td data-bbox="507 342 978 423">Normal operation</td> <td data-bbox="978 342 1230 423">Green : Steadily lit</td> <td data-bbox="1230 342 1321 423"></td> <td data-bbox="1321 342 1538 423"></td> </tr> <tr> <td data-bbox="507 423 978 504">Remote off</td> <td data-bbox="978 423 1230 504">Red : Steadily lit</td> <td data-bbox="1230 423 1321 504"></td> <td data-bbox="1321 423 1538 504"></td> </tr> <tr> <td data-bbox="507 504 978 584">Internal over-temperature</td> <td data-bbox="978 504 1230 584">Orange : 1 Blink/Pause</td> <td data-bbox="1230 504 1321 584"></td> <td data-bbox="1321 504 1538 584"></td> </tr> <tr> <td data-bbox="507 584 978 665">Overload/Short</td> <td data-bbox="978 584 1230 665">Red : 1 Blink/Pause</td> <td data-bbox="1230 584 1321 665"></td> <td data-bbox="1321 584 1538 665"></td> </tr> <tr> <td data-bbox="507 665 978 745">Over voltage</td> <td data-bbox="978 665 1230 745">Red : 2 Blink/Pause</td> <td data-bbox="1230 665 1321 745"></td> <td data-bbox="1321 665 1538 745"></td> </tr> <tr> <td data-bbox="507 745 978 826">Over temperature</td> <td data-bbox="978 745 1230 826">Red : 3 Blink/Pause</td> <td data-bbox="1230 745 1321 826"></td> <td data-bbox="1321 745 1538 826"></td> </tr> <tr> <td data-bbox="507 826 978 907">Fan fail</td> <td data-bbox="978 826 1230 907">Red : 4 Blink/Pause</td> <td data-bbox="1230 826 1321 907"></td> <td data-bbox="1321 826 1538 907"></td> </tr> <tr> <td data-bbox="507 907 978 987">AC under voltage</td> <td data-bbox="978 907 1230 987">Red : 5 Blink/Pause</td> <td data-bbox="1230 907 1321 987"></td> <td data-bbox="1321 907 1538 987"></td> </tr> <tr> <td data-bbox="507 987 978 1077">Others (Note)</td> <td data-bbox="978 987 1230 1077">Red : 6 Blink/Pause</td> <td data-bbox="1230 987 1321 1077"></td> <td data-bbox="1321 987 1538 1077"></td> </tr> </tbody> </table> <p data-bbox="507 1093 1538 1144">Note: 1. Others include hardware fault etc. 2. In PC mode, both OLP and SCP operate in constant current limiting, with the indicator steadily lit green.</p> <p data-bbox="507 1189 663 1323">I/P:230VAC O/P:FULL LOAD Ta:25°C TEST :PASS</p>			Description	Output of alarm			Normal operation	Green : Steadily lit			Remote off	Red : Steadily lit			Internal over-temperature	Orange : 1 Blink/Pause			Overload/Short	Red : 1 Blink/Pause			Over voltage	Red : 2 Blink/Pause			Over temperature	Red : 3 Blink/Pause			Fan fail	Red : 4 Blink/Pause			AC under voltage	Red : 5 Blink/Pause			Others (Note)	Red : 6 Blink/Pause		
Description	Output of alarm																																											
Normal operation	Green : Steadily lit																																											
Remote off	Red : Steadily lit																																											
Internal over-temperature	Orange : 1 Blink/Pause																																											
Overload/Short	Red : 1 Blink/Pause																																											
Over voltage	Red : 2 Blink/Pause																																											
Over temperature	Red : 3 Blink/Pause																																											
Fan fail	Red : 4 Blink/Pause																																											
AC under voltage	Red : 5 Blink/Pause																																											
Others (Note)	Red : 6 Blink/Pause																																											
9	FAN NOISE (Typ.)	<p>10% load @18 dB 70% load @24 dB</p> <p>Built-in intelligent fan speed control detect by PSU' S internal temperature</p>	<p>I/P : 230 VAC O/P : TESTING Ta : 25°C</p>	<p>10% load: 16.39dB 70% load: 23.33dB</p>																																								

COMPONENT STRESS TEST

NO	TEST ITEM	SPECIFICATION	TEST CONDITION	RESULT
1	PWM Transistor (D to S) or (C to E) Peak Voltage	Q53 Rated:650V/33.7A	<p>AC ON/OFF</p> <p>I/P:High-Line +3V =308V</p> <p>VDS:</p> <p>O/P: (1)Full Load (2)Output Short (3)Dynamic Load Full Load/ Min. Load 90%Duty/1KHz (4)Dynamic Load Full Load/ Min. Load 90%Duty/3KHz (5)Dynamic Load Full Load/ Min. Load 90%Duty/5KHz (6)Dynamic Load 100% Load/ Min. Load 50%Duty/120Hz (7)0%→400% Load. (8)0%~150%LOAD (9)0%LOAD~SHORT</p> <p>I/P:Low-Line -3V = 82V</p> <p>O/P: (1)Full Load (2)Output Short (3)Dynamic Load Full Load/ Min. Load 90%Duty/1KHz (4)Dynamic Load Full Load/ Min. Load 90%Duty/3KHz (5)Dynamic Load Full Load/ Min. Load 90%Duty/5KHz (6)Dynamic Load 100% Load/ Min. Load 50%Duty/120Hz (7)0%→400% Load.</p> <p>Ta:25°C</p>	<p>VDS:</p> <p>(1) 456V (2) 442V (3) 504V (4) 500V (5) 504V (6) 512V (7) 516V (8) 43.2V (9) 51.3V</p> <p>VDS:</p> <p>(1) 540V (2) 520V (3) 516V (4) 516V (5) 512V (6) 504V (7) 508V</p>
2	P.F.C Transistor (D to S) or (C to E) Peak Voltage	Q1 Rated: 650V/53A	<p>I/P:High-Line +3V =308V</p> <p>AC ON/OFF</p> <p>O/P: (1)Full Load (2)Output Short (3)Dynamic Load Full Load/ Min. Load 90%Duty/1KHz (4)Dynamic Load Full Load/ Min. Load 90%Duty/3KHz (5)Dynamic Load Full Load/ Min. Load 90%Duty/5KHz (6)Dynamic Load 100% Load/ Min. Load 50%Duty/120Hz (7)0%→400% Load.</p>	<p>VDS:</p> <p>(1) 466V (2) 433V (3) 462V (4) 466V (5) 450V (6) 441V (7) 433V</p>



			<p>I/P:Low-Line -3V =82V AC ON/OFF O/P: (1)Full Load (2)Output Short (3)Dynamic Load Full Load/ Min. Load 90%Duty/1KHz (4)Dynamic Load Full Load/ Min. Load 90%Duty/3KHz (5)Dynamic Load Full Load/ Min. Load 90%Duty/5KHz (6)Dynamic Load 100% Load/ Min. Load 50%Duty/120Hz (7)0%→400% Load. Ta:25°C</p>	<p>VDS: (1) 582V (2) 614V (3) 614V (4) 606V (5) 622V (6) 534V (7) 458V</p>
3	P.F.C DIODE	D4 Rated: 20A/650V	<p>I/P:High-Line +3V =308 V AC ON/OFF O/P: (1)Full Load (2)Output Short (3)Dynamic Load Full Load/ Min. Load 90%Duty/5KHz (4)Dynamic Load 100% Load/ Min. Load 50%Duty/120Hz</p> <p>I/P:Low-Line -3V = 82V AC ON/OFF O/P: (1)Full Load (2)Output Short (3)Dynamic Load Full Load/ Min. Load 90%Duty/5KHz (4)Dynamic Load 100% Load/ Min. Load 50%Duty/120Hz Ta:25°C</p>	<p>(1) 483V (2) 483V (3) 504V (4) 508V (1) 524V (2) 495V (3) 532V (4) 520V</p>
4	Diode Peak Voltage	<p>Q100 Rated 60A/250V</p> <p>Q103 Rated 60A/250V</p>	<p>AC ON/OFF I/P:High-Line +3V =308 V O/P: (1)Full Load (2)Output Short (3)Dynamic Load Full Load/ Min. Load 90%Duty/1KHz (4)Dynamic Load Full Load/ Min. Load 90%Duty/3KHz (5)Dynamic Load Full Load/ Min. Load 90%Duty/5KHz (6)Dynamic Load 100% Load/ Min. Load 50%Duty/120Hz (7)0%→400% Load. (8).NO LOAD Ta:25°C</p>	<p>Q101: VDS: (1) 180V (2) 169V (3) 189V (4) 199V (5) 169V (6) 169V (7) 171V (8) 183V</p>

				<p>Q104: VDS: (1) 185V (2) 163V (3) 181V (4) 177V (5) 183V (6) 173V (7) 157V (8) 185V</p>
5	Input Capacitor Voltage	<p>C5 Rated: 470μ/450V Surge voltage: 495V</p>	<p>I/P:High-Line +3V =308V O/P: (1)Full Load input on/off (2) Min load input on /Off (3)Full Load /Min load Change (4)Full load continue Ta:25°C</p>	<p>(1)454V (2)446V (3)458V (4) 446V</p>
6	Control IC Voltage Test	<p>PWM IC U500 Rated: 8V~30V PFC IC U1 Rated: 11.9V~25V O/P IC U100 Rated: 4.2V~30V</p>	<p>AC ON/OFF I/P:High-Line +3V =308 V O/P(1)FULL LOAD (2) Output Short (3)O.L.P (4)O.V.P. (5)NO LOAD VRmin(Low LINE) Ta:25°C</p>	<p>U500 (1) 17V (2) 17.2V (3) 17V (4) 17.2V (5) 17.2V U1: (1) 17.8V (2) 18V (3) 17.8V (4) 17.6V (5) 17.8V U100 (1) 12.26V (2) 12.26V (3) 12.18V (4) 12.18V (5) 12.18V</p>

■ SAFETY & E.M.C. TEST

SAFETY TEST

NO	TEST ITEM	SPECIFICATION	TEST CONDITION	RESULT
1	WITHSTAND VOLTAGE	I/P-O/P: 4 K VAC/min I/P-FG : 2 K VAC/min O/P-FG: 1.5 KVAC/min	I/P-O/P: 4.4 KVAC/min I/P-FG: 2.4 KVAC/min O/P-FG: 1.8 KVAC/min Ta:25°C	I/P-O/P: 3.254 mA I/P-FG: 2.821 mA O/P-FG: 1.849 mA NO DAMAGE
2	ISOLATION RESISTANCE	I/P-O/P: 500 VDC>100MΩ I/P-FG: 500 VDC>100MΩ O/P-FG: 500 VDC >100MΩ	I/P-O/P: 500 VDC I/P-FG: 500 VDC O/P-FG: 500 VDC Ta:25°C	I/P-O/P: >9999 MΩ I/P-FG: 9999 MΩ O/P-FG: 9999 MΩ NO DAMAGE
3	GROUNDING CONTINUITY	FG(PE) TO CHASSIS OR TRACE < 100 mΩ	40A / 2min Ta:25°C	14mΩ

E.M.C TEST

NO	TEST ITEM	SPECIFICATION	TEST CONDITION	RESULT
1	HARMONIC	EN61000-3-2 CLASS A	I/P:230VAC/50HZ O/P:FULL LOAD Ta:25°C	PASS
2	CONDUCTION	EN55032 EN55014-1 EN55011	I/P : 230 VAC (50HZ) O/P : FULL/50% LOAD Ta : 25°C	PASS Test by certified Lab
3	RADIATION	EN55032 EN55014-1 EN55011	I/P : 230 VAC (50HZ) O/P : FULL LOAD Ta : 25°C	PASS Test by certified Lab
4	E.S.D	EN61000-4-2 AIR : 15KV / Contact : 8KV	I/P : 230 VAC/50HZ O/P : FULL LOAD Ta : 25°C	CRITERIA A
5	E.F.T	EN61000-4-4 INPUT : 2KV	I/P : 230 VAC/50HZ O/P : FULL LOAD Ta : 25°C	CRITERIA A
6	SURGE	IEC61000-4-5 L-N : 2KV L,N-PE : 4KV	I/P : 230 VAC/50HZ O/P : FULL LOAD Ta : 25°C	CRITERIA A
7	Test by certified Lab & Test Report Prepare Any contradictions of the test results, please refer to the latest EMC test report			

■ RELIABILITY TEST

ENVIRONMENT TEST

NO	TEST ITEM	SPECIFICATION	TEST CONDITION	RESULT																																																																																																								
1	TEMPERATURE RISE TEST	MODEL : NSP-1000-48 1. ROOM AMBIENT BURN-IN : 2HRS I/P : 230VAC O/P : FULL LOAD Ta=30.2 °C 2. HIGH AMBIENT BURN-IN : 2HRS I/P : 230VAC O/P : FULL LOAD Ta=60.7 °C																																																																																																										
				<table border="1"> <thead> <tr> <th>NO</th> <th>Position</th> <th>ROOM AMBIENT Ta=30.2 °C</th> <th>HIGH AMBIENT Ta=60.7 °C</th> </tr> </thead> <tbody> <tr><td>1</td><td>LF2</td><td>37.1°C</td><td>67.6°C</td></tr> <tr><td>2</td><td>BD1</td><td>55.4°C</td><td>85.9°C</td></tr> <tr><td>3</td><td>Q1</td><td>52.6°C</td><td>83.1°C</td></tr> <tr><td>4</td><td>D4</td><td>50.7°C</td><td>81.2°C</td></tr> <tr><td>5</td><td>L1</td><td>44.1°C</td><td>74.6°C</td></tr> <tr><td>6</td><td>C5</td><td>39.8°C</td><td>70.3°C</td></tr> <tr><td>7</td><td>U1</td><td>43.5°C</td><td>74.0°C</td></tr> <tr><td>8</td><td>U2</td><td>46.2°C</td><td>76.7°C</td></tr> <tr><td>9</td><td>Q50</td><td>49.6°C</td><td>80.1°C</td></tr> <tr><td>10</td><td>Q51</td><td>50.2°C</td><td>80.7°C</td></tr> <tr><td>11</td><td>Q52</td><td>46.8°C</td><td>77.3°C</td></tr> <tr><td>12</td><td>Q53</td><td>46.5°C</td><td>77.0°C</td></tr> <tr><td>13</td><td>L3</td><td>71.9°C</td><td>102.4°C</td></tr> <tr><td>14</td><td>T1</td><td>73.8°C</td><td>104.3°C</td></tr> <tr><td>15</td><td>D100</td><td>54.5°C</td><td>85.0°C</td></tr> <tr><td>16</td><td>L100</td><td>53.1°C</td><td>83.6°C</td></tr> <tr><td>17</td><td>C110</td><td>41.6°C</td><td>72.1°C</td></tr> <tr><td>18</td><td>U100</td><td>62.1°C</td><td>92.6°C</td></tr> <tr><td>19</td><td>Q102</td><td>51.9°C</td><td>82.4°C</td></tr> <tr><td>20</td><td>R118</td><td>58.9°C</td><td>89.4°C</td></tr> <tr><td>21</td><td>RTH5</td><td>37.6°C</td><td>68.1°C</td></tr> <tr><td>22</td><td>RTH6</td><td>49.2°C</td><td>79.7°C</td></tr> <tr><td>23</td><td>RT31</td><td>44.9°C</td><td>75.4°C</td></tr> <tr><td>24</td><td>RT32</td><td>43.8°C</td><td>74.3°C</td></tr> <tr><td>25</td><td>C14</td><td>37.4°C</td><td>67.9°C</td></tr> </tbody> </table>	NO	Position	ROOM AMBIENT Ta=30.2 °C	HIGH AMBIENT Ta=60.7 °C	1	LF2	37.1°C	67.6°C	2	BD1	55.4°C	85.9°C	3	Q1	52.6°C	83.1°C	4	D4	50.7°C	81.2°C	5	L1	44.1°C	74.6°C	6	C5	39.8°C	70.3°C	7	U1	43.5°C	74.0°C	8	U2	46.2°C	76.7°C	9	Q50	49.6°C	80.1°C	10	Q51	50.2°C	80.7°C	11	Q52	46.8°C	77.3°C	12	Q53	46.5°C	77.0°C	13	L3	71.9°C	102.4°C	14	T1	73.8°C	104.3°C	15	D100	54.5°C	85.0°C	16	L100	53.1°C	83.6°C	17	C110	41.6°C	72.1°C	18	U100	62.1°C	92.6°C	19	Q102	51.9°C	82.4°C	20	R118	58.9°C	89.4°C	21	RTH5	37.6°C	68.1°C	22	RTH6	49.2°C	79.7°C	23	RT31	44.9°C	75.4°C	24	RT32	43.8°C	74.3°C	25	C14	37.4°C	67.9°C
NO	Position	ROOM AMBIENT Ta=30.2 °C	HIGH AMBIENT Ta=60.7 °C																																																																																																									
1	LF2	37.1°C	67.6°C																																																																																																									
2	BD1	55.4°C	85.9°C																																																																																																									
3	Q1	52.6°C	83.1°C																																																																																																									
4	D4	50.7°C	81.2°C																																																																																																									
5	L1	44.1°C	74.6°C																																																																																																									
6	C5	39.8°C	70.3°C																																																																																																									
7	U1	43.5°C	74.0°C																																																																																																									
8	U2	46.2°C	76.7°C																																																																																																									
9	Q50	49.6°C	80.1°C																																																																																																									
10	Q51	50.2°C	80.7°C																																																																																																									
11	Q52	46.8°C	77.3°C																																																																																																									
12	Q53	46.5°C	77.0°C																																																																																																									
13	L3	71.9°C	102.4°C																																																																																																									
14	T1	73.8°C	104.3°C																																																																																																									
15	D100	54.5°C	85.0°C																																																																																																									
16	L100	53.1°C	83.6°C																																																																																																									
17	C110	41.6°C	72.1°C																																																																																																									
18	U100	62.1°C	92.6°C																																																																																																									
19	Q102	51.9°C	82.4°C																																																																																																									
20	R118	58.9°C	89.4°C																																																																																																									
21	RTH5	37.6°C	68.1°C																																																																																																									
22	RTH6	49.2°C	79.7°C																																																																																																									
23	RT31	44.9°C	75.4°C																																																																																																									
24	RT32	43.8°C	74.3°C																																																																																																									
25	C14	37.4°C	67.9°C																																																																																																									
2	OVER LOAD BURN-IN TEST	NO DAMAGE 1 HOUR (MIN)	I/P : 230 VAC O/P : 112 % LOAD Ta : 25°C	TEST : OK																																																																																																								
3	LOW TEMPERATURE TURN ON TEST	TURN ON AFTER 2 HOUR	I/P : 305VAC/100VAC O/P : 60%/ 100 % LOAD Ta= -45/-35 °C	TEST : OK																																																																																																								



4	HIGH HUMIDITY HIGH TEMPERATURE HIGH VOLTAGE TURN ON TEST	AFTER 12 HOURS IN CHAMBER ON CONTROL 60 °C/95 %R.H NO DAMAGE	I/P : 315 VAC O/P : FULL LOAD Ta= 65 °C HUMIDITY= 95 %R.H	TEST : OK
5	TEMPERATURE COEFFICIENT	±0.03 %/°C(0~60°C)	I/P : 230 VAC O/P : FULL LOAD	± 0.003 %/°C(0~60°C)
6	STORAGE TEMPERATURE TEST	-40~85°C	1. Thermal shock Temperature : -45°C~ +90°C 2. Temperature change rate : 25°C / MIN 3. Dwell time low and high temperature : 30 MIN/EACH 4. Total test cycle : 10 CYCLE 5. Input/output condition : STATIC	
7	THERMAL SHOCK TEST	-30~60°C	1. Thermal shock Temperature : -35°C~ +65°C 2. Temperature change rate : 25°C / MIN 3. Dwell time low and high temperature : 30 MIN/EACH 4. Total test cycle : 16 CYCLE 5. Input/output condition : 15cycle:230V/ FULL LOAD AC ON 3sec/AC OFF 1sec TEST 1cycle:230V/ FULL LOAD Burn In Test	
8	VIBRATION TEST	10 ~ 500Hz, 2G 10min./1cycle, 60min. each along X, Y, Z axes	(1) Waveform : Sine Wave (2) Frequency : 10~500Hz (3) Sweep Time : 10min/sweep cycle (4) Acceleration : 3G (5) Test Time : 180min in each axis (X.Y.Z) (6) Ta : 25°C	
9	CAPACITOR LIFE CYCLE	SUPPOSE C110 IS THE MOST CRITICAL COMPONENT (1) I/P : 230VAC O/P : FULL LOAD Ta=25 °C LIFE TIME (2) I/P : 230VAC O/P : FULL LOAD Ta=60 °C LIFE TIME (3) I/P : 230VAC O/P : 75% LOAD Ta=60 °C LIFE TIME (4) I/P : 230VAC O/P : 50% LOAD Ta=60 °C LIFE TIME	(1) 951714HRS (2) 148506HRS (3) 187577HRS (4) 226499HRS	
10	MTBF	Conducted by Parts Stress Analysis Prediction 910.8K hrs min. Telcordia SR-332 (Bellcore) ; 87.5K hrs min. MIL-HDBK-217F (25°C)		
11	Ongoing Reliability Test	I/P : 230VAC O/P : FULL LOAD TA=50°C Demonstration Mean Time Between Failure : 50,000 hours		

TEST RESULT	TESTER	REVIEW	APPROVAL
PASS	WUWQIN/ZHOUBIAO	WENF	WUWQ

2020.10.1 TAG-QA-009